

## PTBS-GET

Junction box for electric heat tracing systems

MULTIPLE-ENTRY SQUARE POWER CONNECTION WITH JUNCTION BOX

- ★ Available for use in hazardous and non-hazardous areas
- ★ Up to 3 HTR heating cables connected
- ★ PTBS-GET is used with HTR heating cable family
- ★ Silicone-free core seal for easy installation

- ★  Class1.Div2, Group A,B,C,D  
Class2.Div2, Group E,F,G  
Class3.Div2,

### PRODUCT OVERVIEW

The PTBS-GET kit is designed to connect power to HTR heating cables. It is approved by CSA for use in hazardous and non-hazardous areas.

The PTBS-GET integrates the functions of connection kits and insulation entries. The rugged stand protects the heating cable and allows up to 132 mm of thermal insulation.

PTBS-GET contains all the necessary materials for a complete certified installation.

The innovative spring clamp terminals provide safe, reliable, maintenance-free operation.

The PTBS-GET core seal offers a silicone-free installation.

### SPECIFICATIONS

Minimum installation temperature	-40°C(-40°F)
Size L*W*H	120*120*90 mm
Material	Glass reinforced Polyester, Fire Retardant

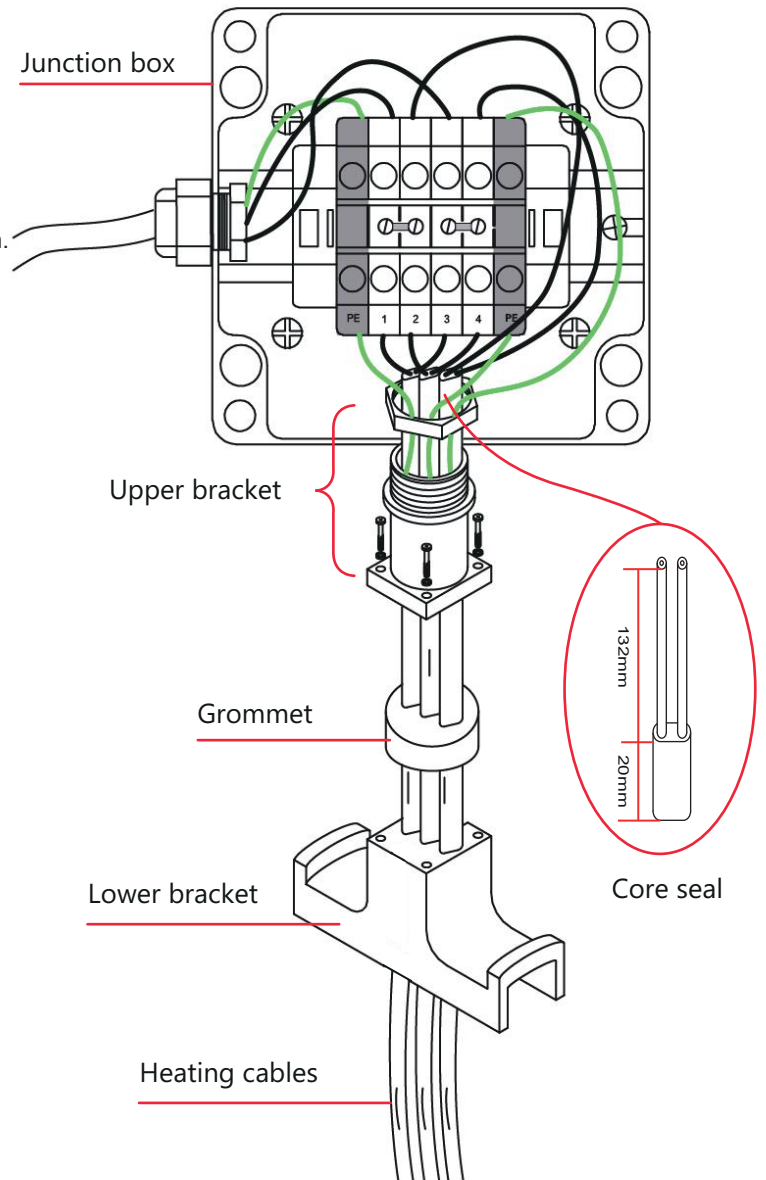

## Installation Instructions

1. Push with strength 1, 2 or 3 heating cables from the bottom of the lower bracket through and leave 300mm exposed.

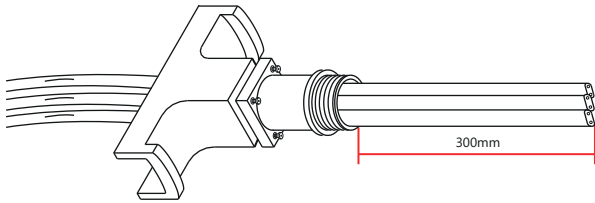

2. Lightly cut around cable jacket 165mm from the end of cable. Bend cable to break jacket. Lightly cut the jacket up the center between the first cut mark and the end of cable. Bend cable to break jacket. Remove the jacket from the heating cable.

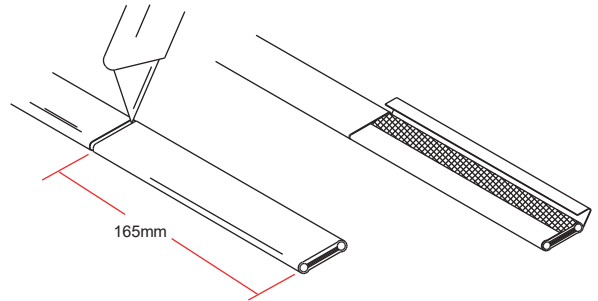

3. Move braid back toward the overjacket, creating a bulge. At the bulge, separate the braid to make an opening.

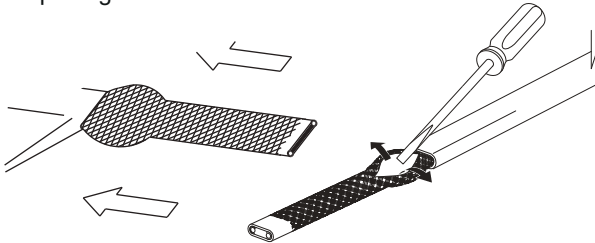

4. While bending the heating cable, work it through the braid opening. Pull the braid tight.

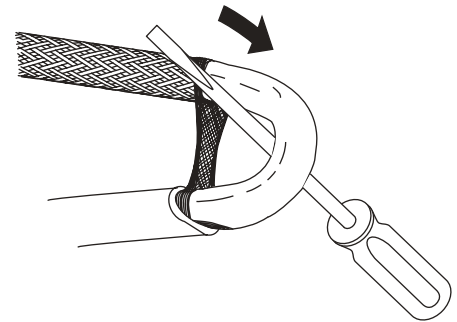

5. Lightly cut around cable insulation 145mm from the end of cable. Bend cable to break the insulation. Lightly cut the insulation up the center between the first cut mark and the end of cable. Bend cable to break jacket. Remove the insulation.

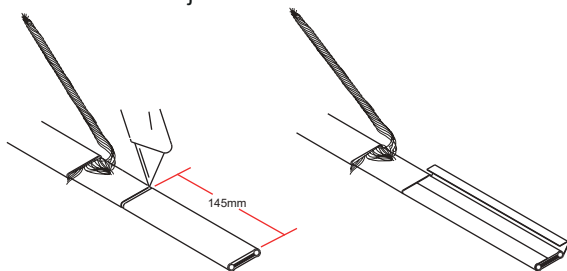

6. Shave off out matrix material from each bus wires with a utility knife.

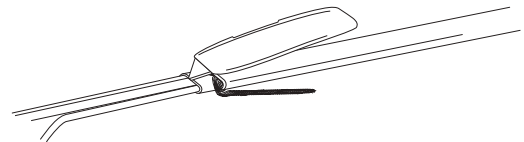

7. Peel back exposed wires from central matrix. **DO NOT CUT THE BUS WIRES.**

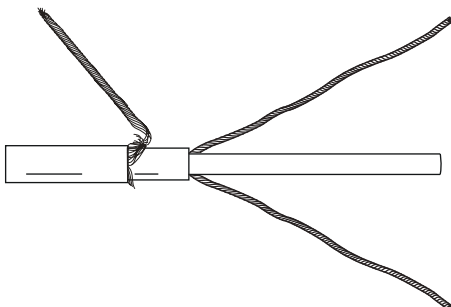

8. Cut off the exposed matrix. **DO NOT CUT THE BUS WIRES.**

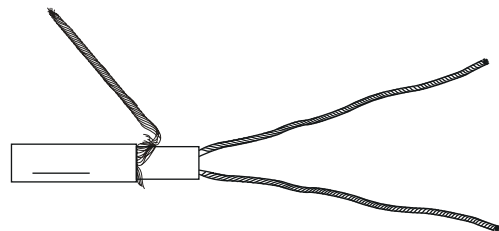

9. Insert the bus wires through a core seal.  
Insert the braiding through a yellow-green tube.

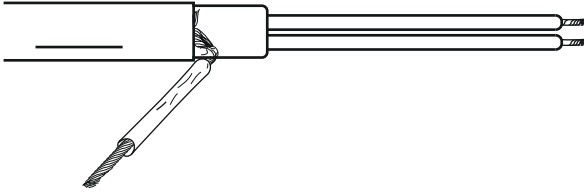

10. If there is a second or third cable, repeat step 2 to step 9.

12. Insert the cables through the lower entry of the junction box.  
Lock the bracket with the junction box by the lock ring.  
Connect the bus wires (black) and ground wires (green) to the nuts as shown.

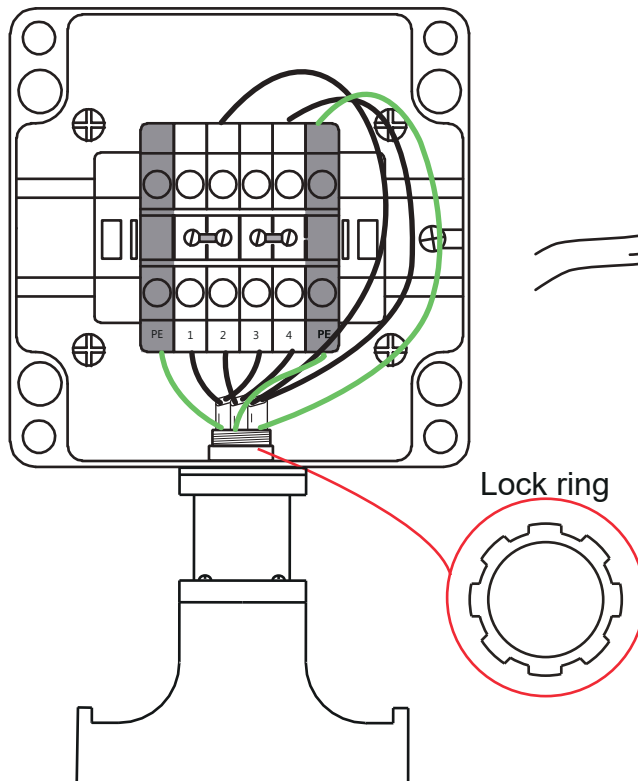

11. Pull back the heating cables, leaving 132mm core seal exposed. Tighten the 4 screws.

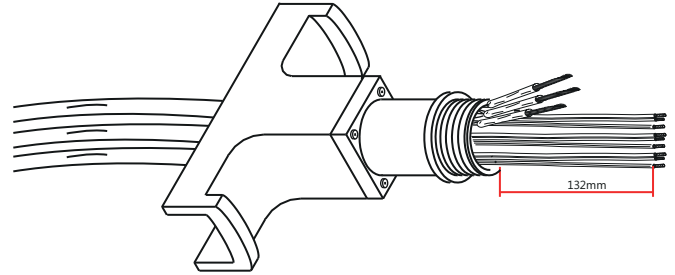

13. Connect the power wires (black) and ground wires (green) to the nuts as shown.

